

Barefooted and  
burning feet

Glenn Erik Haugland

• thanx to some David  
Bovies of the past,

BAREFOOTED AMONG BURNING FEET

" I am bored of the events, I really don't understand the situation.

Changing to the others situation, understanding is just being a part.

Communicating in motions; I'll dance my life away."

1-1-1-1 1-1-1 2 perc. 2soprano 2mezzo-soprano vln.-vla-vcl-cb

perc.1) Marimba, anvil, cymbals (large-small), bongos

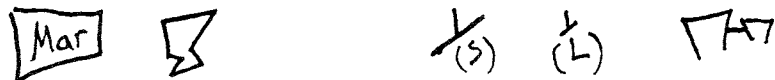

perc.2) 4 Wooddrums, 4 Tom-tom, snare-drum



In orchestras with forex. 20 violins, the parts should be divided as:  
I orkestrer med foreks. 20 violiner fordeles stemmene slik:

1.VLN.- 5

2.VLN.- 5

3.VLN.- 10

The singers should be amplified in general at places where they sing along with the orchestra.  
At "con mic.", the singers should use "close microphones" with a pop-like echo sound.

Sangerene bør generelt forsterkes når de optrer sammen med orkesteret, dette for å unngå  
"opera-klang". På "con mic" bør sangerene bruke nære mikrofoner med en pop lignende echo-klang.

Prepared Piano : Light chain on the deeper strings.  
Lett kjetting på de dype strengene.

Some sign-explanations:

Noen tegn forklaringer:

• = damping  
• = dempes

U = pitch bend  
= tonehøyde bøyes

sp, sf = subito piano or forte

"scratch" = bow played so slow that it produces a scratching sound

= buen strykes så sakte at tonen blir forvrengt.

For other signs, see: Kurt Stone: Music Notation in the Twentieth Century

durata: ca. 13min.

Flute

Oboe

Clar.

Bassoon

Horn

Trumpet

Trombone

Perc. I

Perc. II

Piano-forte

Sopran I

II

Mezzo Sopran I

II

Violin

Vla.

V.cl.

Double Bass

mp

mf

p

f

st. mute

mp

TE MPO 1  
60-70

ai y → m ai 3 iai → iai-iai-

aim mai-m m jai ma →

2. solo

solo con sordino

solo

pp mp pp

mp

f

mp

mp

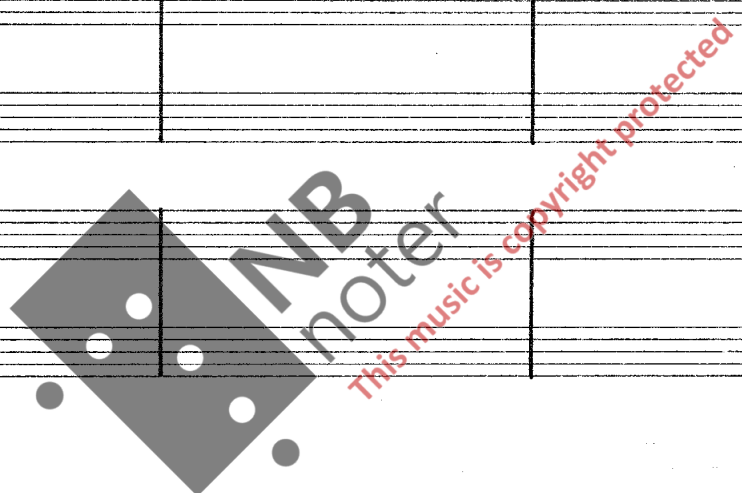

Flute  
 Oboe  
 Clar.  
 Bassoon  
 Horn  
 Trumpet  
 Trombone

Musical score for woodwinds and brass instruments. The Flute part features triplets and dynamics like *p*, *mp*, *f*, and *mp*. The Bassoon part has a *mf* dynamic. The Horn and Trumpet parts include triplets and *mp* dynamics. The Trombone part has a *mp* dynamic.

Perc. I

Perc. II

Piano forte

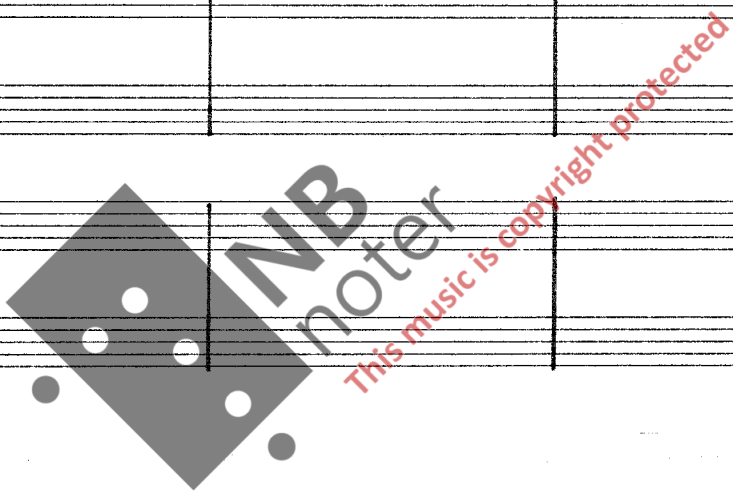

Sopran I

Sopran II

Mezzo Sopran I

ai →  
ai →

Mezzo Sopran II

ia →  
ia →

Violin

1. solo *ppp* *f* *mp* *p*

Vla.

*ppp* *f* *mp* *p*

Vcl.

*ppp* *f* *mp* *p*

Double Bass

*ppp* *f* *mp* *p*

Flute

Oboe

Clar.

Bassoon

Horn

Trumpet

Trombone

Perc. I

Perc. II

Piano-forte

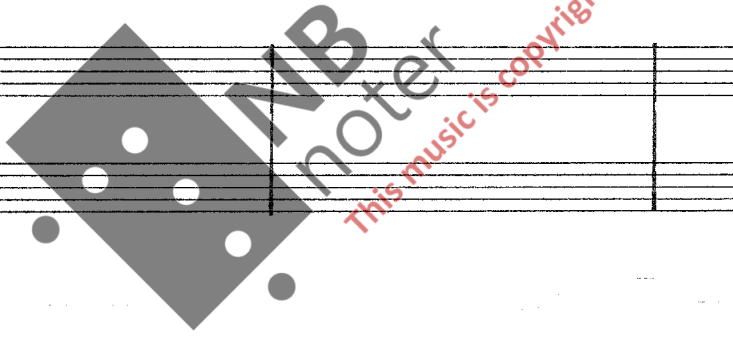

10

Soprano I

Soprano II

Mezzo Soprano I

Mezzo Soprano II

Violin

Vla.

Vcl.

Double Bass



Picc. Flute)  
 Oboe  
 Clar.  
 Bassoon

Horn  
 Trumpet  
 Trombone

Perc. I

Perc. II

Piano-forte

20

Soprano I  
 II  
 Mezzo-soprano I  
 II

Violin  
 Vla.  
 Vcl.  
 Double Bass

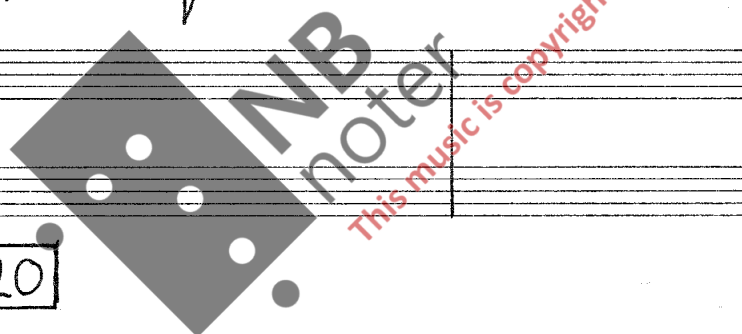

Picc. (Flute)  
 Oboe  
 Clar.  
 Bassoon

Handwritten musical notation for woodwinds. Includes dynamics like *p*, *mf*, *mp*, and *sf*. Features various articulations and slurs.

Horn  
 Trumpet  
 Trombone

Handwritten musical notation for brass instruments. Includes markings like *cup mute* and *con mute*. Dynamics range from *p* to *mp*.

Perc. I  
 Perc. II

Handwritten musical notation for Percussion I and Percussion II. Includes dynamic markings like *mp* and *f*.

Piano forte

Handwritten musical notation for Piano forte. The staff is mostly empty, with a large watermark overlaid.

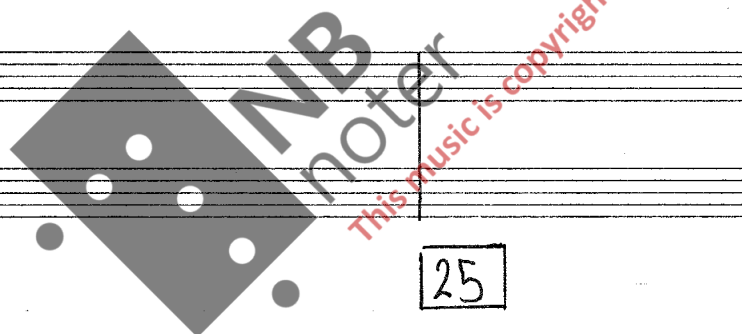

25

Sopran I  
 II  
 Mezzo sopran I  
 II

Empty musical staves for vocal parts: Soprano I, Soprano II, Mezzo Soprano I, and Mezzo Soprano II.

Violin  
 Vla.  
 Vcl.  
 Double Bass

Handwritten musical notation for string instruments. Includes dynamic markings like *sf*, *mp*, *molto*, and *tutti*. Features *col. 1.* (coda) and *one solo* markings.



Picc. (Flute)  
 Oboe  
 Clar.  
 Bassoon  
 Horn  
 Trumpet  
 Trombone  
 Mar.  
 Perc. I  
 Perc. II  
 Piano-forte  
 Sopran I  
 II  
 Mezzo soprano I  
 II

rit ..... || a tempo

30

Violin  
 Vla.  
 Vcl.  
 Double Bass

con sordino

con sordino

con sordino

tutti con sordino

con sordino

fp (1/4 Vol) (KB) (sfz) sfz

Picc. (Flute)  
 Oboe  
 Clar.  
 Bassoon  
 Horn  
 Trumpet  
 Trombone

Mar.  
 Perc. I

Perc. II

Piano-forte

Sopran I  
 II  
 Mezzo soprano I  
 II

Violin  
 Vla.  
 V.cl.  
 Double Bass

Picc. (Flute)  
Oboe  
Clar. (with *ff solo*)  
Bassoon  
Horn  
Trumpet  
Trombone  
Mar.  
Perc. I  
Perc. II  
Piano-forte  
Soprano I  
Soprano II  
Mezzo-soprano I  
Mezzo-soprano II  
Violin  
Vla.  
Vcl.  
Double Bass

The musical score is written in a standard staff format with various clefs and time signatures. It includes dynamic markings such as *mp*, *p*, *f*, *ff*, and *pp*. Performance instructions like *molto* and *div.* are present. The score is divided into systems, with some measures containing rests or specific articulation marks. A large watermark 'MNB Noter' is visible across the middle of the page.

Picc (Flute)  
 Oboe  
 Clarinet  
 Bassoon

Handwritten musical notation for woodwinds. Includes dynamics like *sp*, *sf*, and *sf* in a box. Features triplets and sixteenth notes.

Horn  
 Trumpet  
 Trombone

Handwritten musical notation for brass instruments. Includes dynamics like *mp* and *f*. Features triplets and notes with slurs.

Mar.  
 Perc. I

Handwritten musical notation for Maracas and Percussion I. Includes dynamics like *mf* and *f*. Features rhythmic patterns and slurs.

Perc. II

Handwritten musical notation for Percussion II. Includes dynamics like *mf*, *sp*, *mp*, and *f*. Features rhythmic patterns and slurs.

Piano-forte

Handwritten musical notation for Piano-forte. Includes dynamics like *sf*. Features a few notes with slurs.

40



Soprano I  
 II  
 mezzo soprano I  
 II

Empty musical staves for vocal parts: Soprano I, II, Mezzo Soprano I, II.

Violin  
 Vla.  
 V.cl.  
 Double Bass

Handwritten musical notation for strings. Includes dynamics like *mf* in a box, *p*, and *f*. Features slurs and notes with slurs. Includes performance instructions like "Senza Sordin", "1. solo", "2. solo", "gliss.", "tutti", and "(con sordin)".

Mata in Flute

Flute

Oboe

Clar.

Bassoon

Horn

Trumpet

Trombone

Mar.

Perc. I

Perc. II

Piano-forte

Sopran I

II

Mezzo sopran I

II

Violin

Vla.

Vcl.

Double Bass

pp

mf

molto f

pp

one solo

3

4

4

45

This music is copyright protected

Flute  
Oboe  
Clarinet  
Bassoon

Horn  
Trumpet  
Trombone

Maracas  
Perc. I

Perc. II

Piano-forte

Soprano I  
Soprano II  
Mezzo-soprano I  
Mezzo-soprano II

Violin  
Viola  
Violoncello  
Double Bass

6/4

4/4

Flute

Oboe

Clarinet

Bassoon

Horn

Trumpet

trombone

Mor Perc. I

Perc. II

Piano-forte

Soprano I

Soprano II

Mezzo-soprano I

Mezzo-soprano II

6

4

4

4

Violin

Vla.

Vcl.

Double Bass

(one solo)





Flute

Oboe

Clar.

Bassoon

Horn

Trumpet

trombone

Mar.  
Perc. I

Perc. II

Piano-forte

Soprano I

II

Mezzo-soprano I

II

Violin

Vla.

Vcl.

Double Bass

Handwritten musical score for various instruments including woodwinds, percussion, strings, and voice. The score includes dynamic markings such as *p*, *mp*, and *pp*, and includes a box containing the number 60. A large watermark 'NMB noter' is visible across the piano and percussion staves.

Flute  
 Oboe  
 Clarinet  
 Bassoon

Mata in Piccolo

*f* *pp* *f* **ff**

Horn  
 Trumpet  
 Trombone

open

**ff**

Mar.  
 Perc. I

8va

*f* *pp*

Perc. II

close to rim

*mf* *pp* *molto ff*

Piano-forte

*f* *pp* *molto ff* **ff**

(Ped) 8va

Soprano I  
 II  
 Mezzo-soprano I  
 II

Violin

**Hatti**

**Senza sordini**

*pp* *p* *f* *aliss.* **ff**

Vla.  
 Vcl.  
 Double Bass

*pp* *pp* *f* *f*

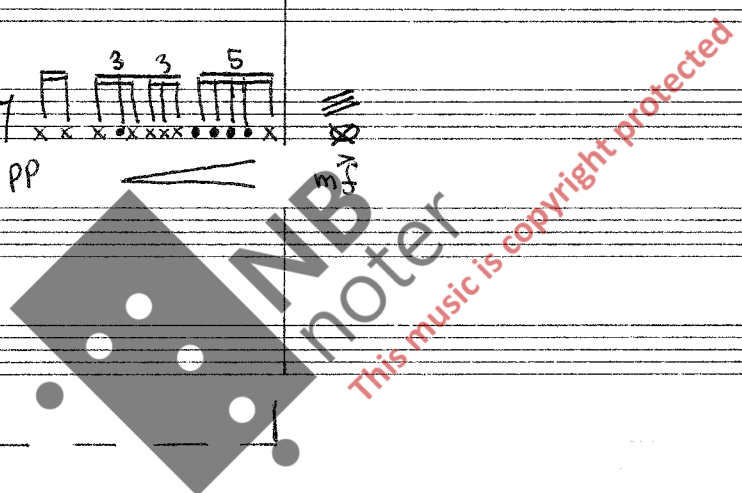



Picc. (Flute) 8va *mf* *muta in flute*

Oboe *mf*

Clarinet *mf*

Bassoon *mf*

Horn *mf* *p*

Trumpet *mf*

Trombone *mf*

Mar. Perc. I *mf*

Perc. II *mf*

Piano-forte *mp* *70*

Soprano I *mf*

Soprano II *mp*

Mezzo-soprano I *mp*

Mezzo-soprano II *mp*

Violin *mf* *8va*

Vla. *molto* *one solo con sordini* *ppp* *molto*

Vcl. *molto*

Double Bass *molto*



2  
4



TEMPO 1

Soprano I  
Soprano II  
Mezzo Soprano I  
Mezzo Soprano II

Handwritten musical score for measures 75-80. It features four vocal staves: Soprano I, Soprano II, Mezzo Soprano I, and Mezzo Soprano II. The lyrics include "iai-aim" and "my ym". Dynamic markings include *ppp*, *mf*, *p*, *mp*, and *gl.*. There are also performance instructions like *3* and *gl.*.

80

Handwritten musical score for measures 80-85. It features four vocal staves. The lyrics include "aim-mai-m" and "my ym". Dynamic markings include *mp*, *mf*, *p*, and *pp*. There are also performance instructions like *3* and *gl.*.

85

Handwritten musical score for measures 85-90. It features four vocal staves. The lyrics include "mai aim", "aim", and "iai-mai m". Dynamic markings include *mp*, *p*, *pp*, and *gl.*. There are also performance instructions like *3* and *gl.*.

90

Handwritten musical score for measures 90-95. It features four vocal staves. The lyrics include "ai-m", "ia-ym", and "ai-m mai". Dynamic markings include *mf*, *mp*, and *p*. There are also performance instructions like *3* and *gl.*.



Flute

Oboe

Clar.

Bassoon

Horn

Trumpet

Trombone

Perc. I

Perc. II

Piano-forte

105

Soprano I

Soprano II

Mezzo Soprano I

Mezzo Soprano II

Violin

Vla.

Vcl.

Double Bass





Flute

Oboe

Clarinet

Bassoon

Horn

Trumpet

trombone

Perc. I

Perc. II

Piano-forte

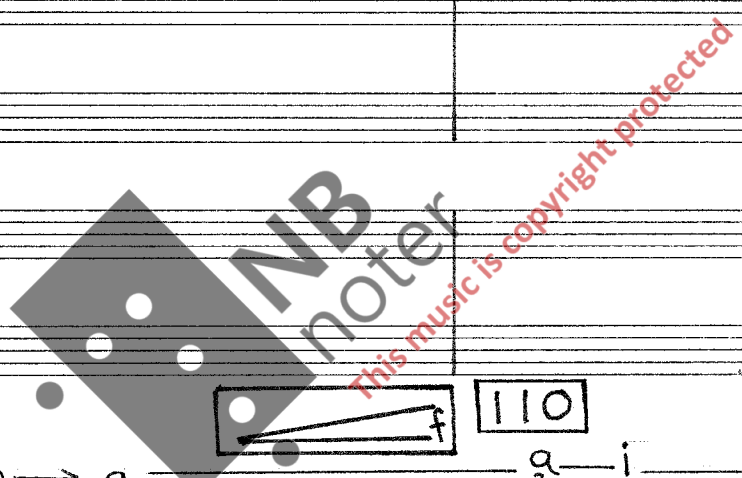

Soprano I

Soprano II

Mezzo-soprano I

Mezzo-soprano II

Lyrics: m → a m → a my ym a m m → a i a m → a my

Violin

Vla.

Vcl.

Double Bass

Flute

Oboe

Clar.

Bassoon

Horn

Trumpet

Trombone

Perc. I

Perc. II

Piano

Violin I

Violin II

Viola

Violoncello

Bass

ai ai m m

nervously

open

mp

Mar

Prepared

115

rit

TEMPO 2

2

4

5

Tutti

ff

115

scratch

Flute

Oboe

Clar.

Bassoon

Horn

Trumpet

trombone

Mar. Perc. I

Perc. II

Piano-forte

\*Ped.

Violin I

Violin II

Violoncello I

Violoncello II

Violin

Vla.

Vcl.

Double Bass

8

Handwritten musical score for page 25, featuring various instruments and dynamic markings.

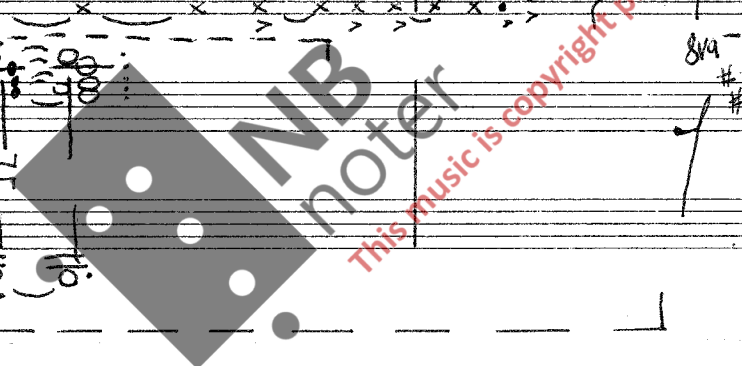

120

1. solo

2. solo

Handwritten musical notation for solo parts with dynamic markings: *ppp*, *p*, *molto*.

Flute  
 Oboe  
 Clar.  
 Bassoon

Horn  
 Trumpet  
 Trombone

Mar.  
 Perc. I

Perc. II

Piano-forte  
 (Ped)

Soprano I  
 II  
 Mezzo soprano I  
 II

Violin  
 Vla.  
 Vcl.  
 Double Bass

Flute

Oboe

Clarinet

Bassoon

Horn

Trumpet

trombone

Mus. Perc. I

Perc. II

close to rim sim →

Piano-forte

125

Violin I

Violin II

Viola

Violoncello

Double Bass

Violin

Viola

Violoncello

Double Bass

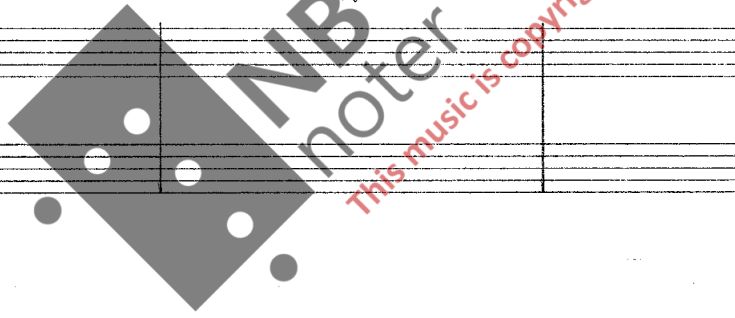

Flute

Oboe

Clar.

Bassoon

Horn

Trumpet

Trombone

Mar.

Perc. I

Perc. II

Piano-forte

130

Sopran I

II

Mezzo Sopran I

II

Violin

Vla.

Vcl.

Double Bass

Flute

Oboe

Clarinet

Bassoon

Horn

Trumpet

Trombone

Mr. Perc. I

Perc. II

Piano-forte

Sopran I

II

Mezzo-sopran I

II

Violin

Vla.

V.cl.

Double Bass

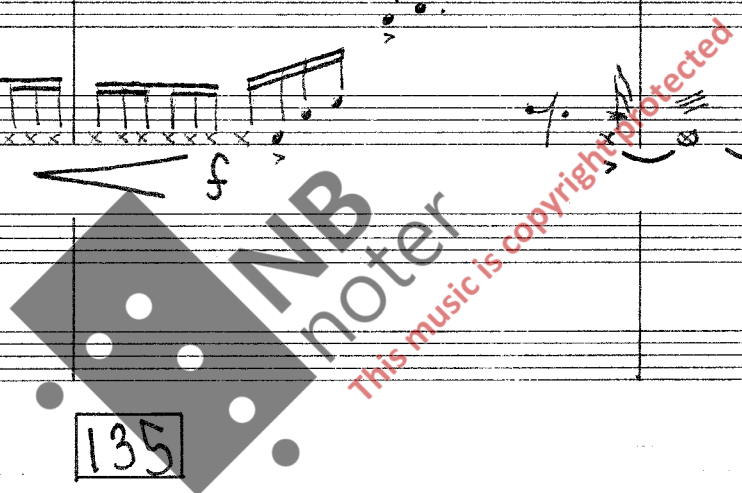





Flute

Oboe

Clar.

Bassoon

Horn

Trumpet

trombone

Mar.  
perc. I

perc. II

Piano  
forte

1. solo  
Vln.

2. solo

Vla solo

Vcl solo

utti 1.

Vcln  
utti 2.

Tutti 3.

Tutti  
Vla.

Tutti  
Vcl.

suble  
Bass

The score is written on a system of staves. The upper staves (Flute, Oboe, Clarinet, Bassoon, Horn, Trumpet, Trombone) are mostly empty. The Maracas and Percussion I staves have a few notes in the final measure. Percussion II has a rhythmic pattern of quarter notes with a '3' below them, marked with 'pp', 'mp', and 'ppp', and a 'morendo' hairpin. The Piano Forte staff is empty. The Violin and Viola staves have complex passages with triplets and slurs, marked with 'p' and 'ppp'. The Violoncello staff has a similar passage marked with 'ppp'. The string ensemble (utti) staves have sustained notes with various dynamics like 'pp' and 'ppp'. The Viola and Violoncello solo parts are marked 'one solo' and 'pp'. A large watermark 'NB noter' is overlaid on the score, with the text 'This music is copyright protected' written diagonally across it. A box containing the number '145' is also present.

Mufa in Piccolo

Piccola (Flute) *mf* 3 3

Oboe *f* 3 3

Clar.

Bassoon

Horn

Trumpet

Trombone

Mari Perc. I *mf* *f* *sim.*

Perc. II *mf* *f* *pp*

Piano forte *mf* *f*

Sopran I

II

Mezzo Sopran I

II

Violin

Vla.

Vcl.

Double Bass

Flute (picc.)  
 Oboe  
 Clarinet  
 Bassoon  
 Horn  
 Trumpet  
 Trombone

Flute (picc.)  
 Flute (I)  
 Flute (II)

Piano  
 Forte

Violin I  
 Violin II  
 Viola  
 Violoncello I  
 Violoncello II

Timpani  
 Bass Drum  
 Snare Drum  
 Cymbals



Picc. (Flute) *8va* *mp* *sf* *mp* *sf*

Oboe *mp* *sf* *mp* *sf*

Clar. *mp* *sf* *mp* *sf*

Bassoon *mp* *sf* *mp* *sf*

Horn *sf* *mp* *sf*

Trumpet *sf* *mp* *sf*

Trombone *sfz* *mp* *sf*

Mar. *p* *f* *mf*

Perc. I *p* *f* *mf*

Perc. II *mf* *f* *mp*

Piano Forte *p* *mp* *sf* *mp* *sf*

*8va* *mp* *sf* *mp* *sf*

*Ped.*

155

Soprano I

Soprano II

Mezzo Soprano I

Mezzo Soprano II

*fff* *pp* *sfz* *mf* non-vib. *sfz*

Violin *8va* *pp* *sfz* *mf* *sfz*

Vla. *pp* *sfz* *mf* *sfz*

V.cl. *pp* *sfz* *mf* *sfz*

Double Bass *pp* *sfz* *mf* *sfz*



Picc. Flute)  
 Oboe  
 Clarinet  
 Bassoon

Trumpet  
 Trombone

Picc.  
 Picc.

Violin I  
 Violin II

Piano  
 Cello

Organ I  
 Organ II  
 Organ III  
 Organ IV

pp ————— f ms non-vib.

Violin  
 Viola  
 Violoncello  
 Double Bass

Picc. (Flute)

Oboe

Clar.

Bassoon

Horn

Trumpet

Trombone

Mar.

Perc. I

Perc. II

Piano-forte

165

Sopran I

II

Mezzo-sopran I

II

(Vln.)

Violin

Vla.

V.cl.

Double Bass

(Vla-Vcl.-kb)









Flute

Oboe

Clarinet

Bassoon

Horn

Trumpet

Trombone

Perc. I

Perc. II

Piano-forte

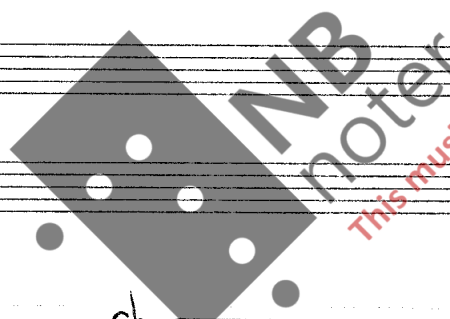

190 **TEMPO 3 (126 - 132)**

Soprano I

Soprano II

Mezzo Soprano I

Mezzo Soprano II

Con Sordin

Violin

Vla.

Vcl.

Double Bass

8

\* to the cha → n ging

u to the cha → n ging

a tions

a tions

con sordin

con sordin

div.

one solo

intens

Flute

Oboe

Clar.

Bassoon

Horn

Trumpet

Trombone

Perc. I

Perc. II

Piano forte

Soprano I

Soprano II

Mezzo Soprano I

Mezzo Soprano II

Violin

Viol. div.

Vla.

Vcl.

Double Bass

played with hand

pp

cresc.

f

195

to

to

the

the

Chang ing

to

Chang ing

to

the

the

tutti con sordin

gliss

pp

tutti con sordin

8

Flute  
 Oboe  
 Clar.  
 Bassoon  
 Horn  
 Trumpet  
 Trombone  
 Perc. I  
 Perc. II  
 Piano-forte  
 Sopran I  
 II  
 Mezzo Sopran I  
 II  
 Violin  
 Vla.  
 Vcl.  
 Double Bass

legato

200

tutti

(cl-kb) dim

3) sfz > played. | sfz > mf > pp |

Flute

Oboe

Clarinet

Bassoon

Handwritten notes: *p*, *legato*, *p*

Horn

Trumpet

Trombone

Perc. I

Handwritten notes: *p*, *mp*, *3*

Perc. II

Piano-forte

Handwritten notes: *dim*, *pp*

205

Soprano I

Soprano II

Mezzo Soprano I

Mezzo Soprano II

Violin

Vla.

Vcl.

Double Bass

Handwritten notes: *gliss*, *gliss*, *gliss*, *pp*, *sf*

Cresc. — norm. —> pc. f



Flute

Oboe

Clarinet

Bassoon

Horn

Trumpet

Trombone

Perc. I

Perc. II

Piano

forte

215

Soprano I

Soprano II

Mezzo Soprano I

Mezzo Soprano II

Violin

Vla.

Vcl.

Double Bass

☉ = drums damped by hand - trommene dempet m/hånden

Flute  
 Oboe  
 Clar.  
 Bassoon

Horn  
 Trumpet  
 Trombone

Perc. I

Perc. II

Piano forte  
 (Ped)

220

Violon I  
 II  
 Violoncello I  
 II

Violin  
 Vla.  
 Vcl.  
 Double Bass

Cresc. --- S  
 norm. --- p.c.





Flute

Oboe

Clarinet

Bassoon

Horn

Trumpet

Trombone

Perc. I

Perc. II

Piano forte

230

Soprano I

Soprano II

Mezzo Soprano I

Mezzo Soprano II

Violin

Vla.

Vcl.

Double Bass

Flute  
 Oboe  
 Clarinet  
 Bassoon

Horn  
 Trumpet  
 Trombone

Perc. I

Perc. II

Piano-forte

Soprano I  
 II  
 Mezzo-soprano I  
 II

Violin  
 Viola  
 Violoncello  
 Double Bass

MB  
 meter  
 This music is copyright protected

235

pc. → norm < sf

Flute  
 Oboe  
 Clar.  
 Bassoon

Handwritten musical notation for woodwinds. Includes dynamics like *mp*, *sfz*, *legato*, *pp*, *fff*, *mf*, and *ff*. Features triplets and slurs.

Horn  
 Trumpet  
 Trombone

Handwritten musical notation for brass instruments. Includes dynamics like *mf*.

Perc. I

Handwritten musical notation for Percussion I. Includes dynamics like *p* and *sfz*, and markings for *norm*.

Perc. II

Handwritten musical notation for Percussion II. Includes dynamics like *p* and *sfz*, and markings for *norm*.

Piano-forte

Handwritten musical notation for Piano-forte. Includes dynamics like *f*.

240

Sopran I  
 II  
 Mezzo sopran I  
 II

Handwritten musical notation for vocal parts. Includes lyrics: "Com-mun-i-ca-ting-in-".

Violin  
 Vla.  
 Vcl.  
 Double Bass

Handwritten musical notation for strings. Includes dynamics like *sfz*, *mf*, *pp*, and *ff*. Features slurs and accents.

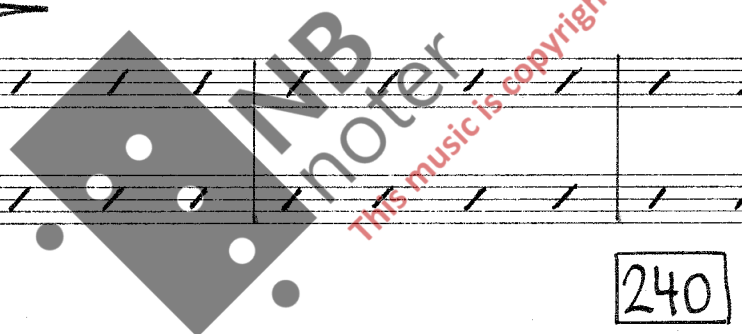



Flute  
 Oboe  
 Clar.  
 Bassoon

Horn  
 Trumpet  
 Trombone

Perc. I

Perc. II

Piano-forte

250

Sopran I  
 II  
 Mezzo Sopran I  
 II

Violin  
 Vla.  
 Vcl.  
 Double Bass

Flute  
 Oboe  
 Clarinet  
 Bassoon

Horn  
 Trumpet  
 Trombone

Perc. I

Perc. II

Piano-forte

(Red)

255

Soprano I  
 II  
 Mezzo-soprano I  
 II

ca ting in mo tio ns  
 ca ting in mo tio ns  
 ca ting in mo tions I'll dance my life a  
 ca ting in mo tions I'll dance my life a

Violin  
 Vla.  
 Vcl.  
 Double Bass

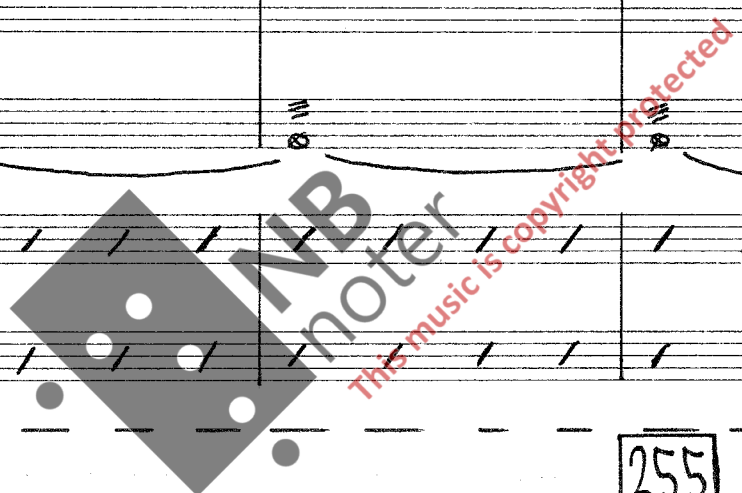

Flute (mf)

Oboe

Clar.

Bassoon

Horn

Trumpet (mp)

Trombone

Perc. I

Perc. II

Piano-forte (pp) (legato)

260

Soprano I

Soprano II

Mezzo Soprano I

Mezzo Soprano II

Violin

Vla.

Vcl.

Double Bass



Flute

Oboe

Clar.

Bassoon

Horn

Trumpet

Trombone

Perc. I

Perc. II

Piano-forte

Sopran I

II

Mezzo Sopran I

II

Violin

Vla.

V.cl.

Double Bass

pp

norm.

3

1

265

Flute

Oboe

Clar.

Bassoon

Horn

Trumpet

Trombone

Perc. I

Perc. II

Piano forte

Soprano I

Soprano II

Mezzo soprano I

Mezzo soprano II

Violin

Vla.

Vcl.

Double Bass

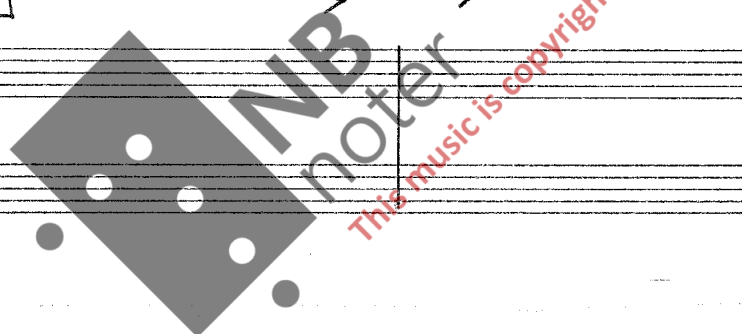

Hegdehaugsvn.  
 27/2-83 Rev. 5/12-83  
 Glenn Erik Haugland