

Sigurd Berge

D for orkester

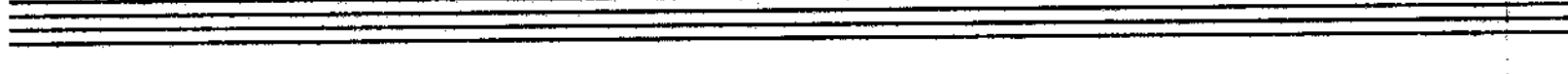
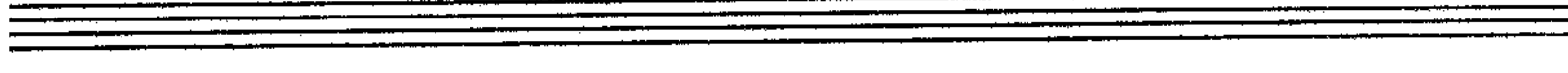
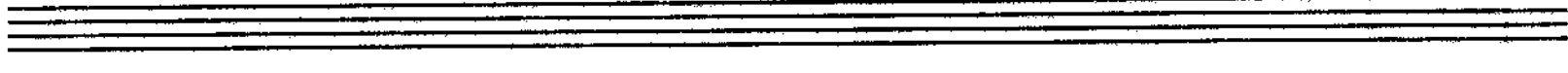
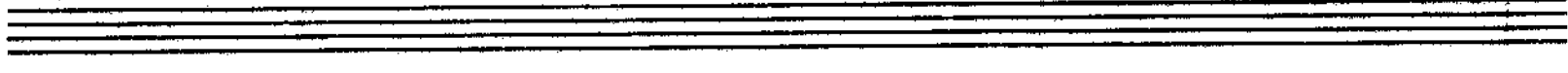
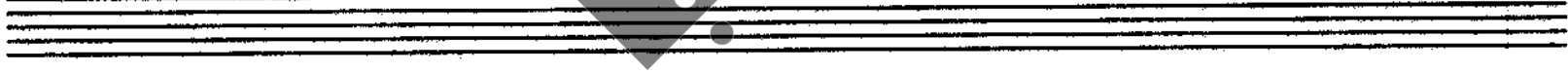
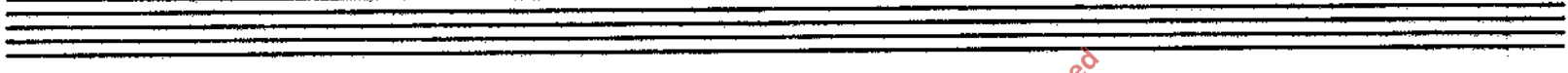

## Orchestra:

- 3 Flutes
- 3 Oboes
- 2 Clarinets in B<sub>b</sub>
- 1 Bass Clarinet in B<sub>b</sub>
- 2 Bassoons
- 1 Double Bassoon
  
- 4 Horns in F
- 3 Trumpets in B<sub>b</sub>
- 3 Trombones

## Percussion (2 players)

- I 3 bongos, 3 tamburi militari (senza corde), 2 casse di legno  
3 tom-tom, 2 ritte susp, tam-tam (piccolo)
- II tamburo rullante (senza corde), gran cassa, 2 casse di legno  
sand block, 2 ritte susp, fusta, 2 tam-tam (medio, grande)

## Timpani

## Strings

Tutti gli strumenti sono scritti in suoni reali, meno il contrabbasso e il contrafagotto (scritti all'8' sopra)

Duration: approximately 6 minutes





NB noter

This music is copyright protected

Violini I <sup>x)</sup>  simile

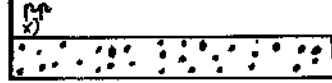
Violini II <sup>mp</sup> <sup>x)</sup>  simile

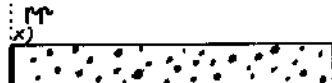
Viola <sup>mp</sup> <sup>x)</sup>  simile

**pp**

**Ve**

**Cb**

**pp**

*dir. gliss.*

*dir. gliss.*

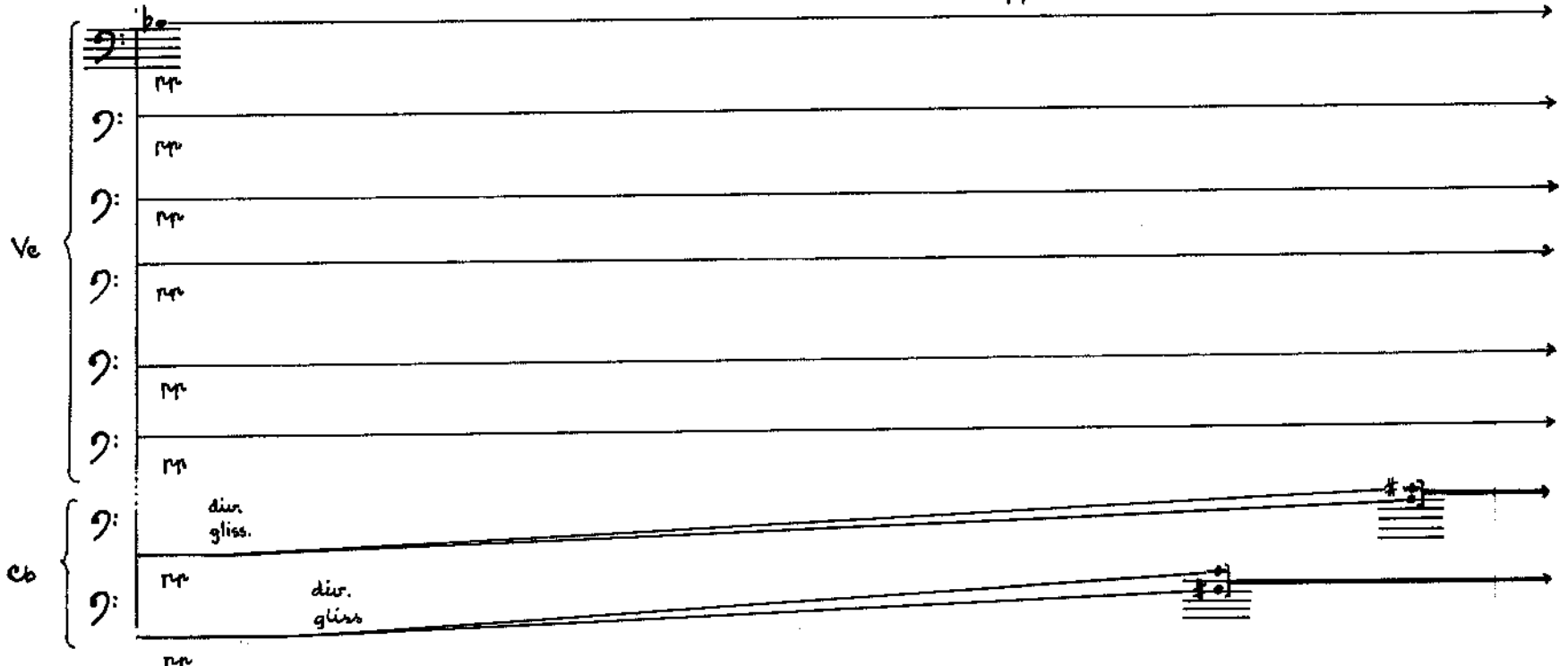

x) Tap the body of the instr. with the fingertips.

Cor 1,2,3,4. *mp* *simile*

Tr. 1,2,3. *mp* *simile*

Trb 1,2,3. *mp* *simile*

Batt 1 *mp* *simile* *xx)* 3 diff. bongos

Batt 2 *mp* *simile* *xx)* tam. rull (senza cord)

Temp *mp* *simile* *xx)* 3 diff. timp.

Vn I

Vn II

Vl

Ve *mp* *gliss.*

Cb *mp* *gliss.* *xxx)* *mp* *simile*

x) *mp* beat mouthpiece with palm      xx) tap the skin with the fingertips      xxx) see page 2.  
 (not synchronized start.)

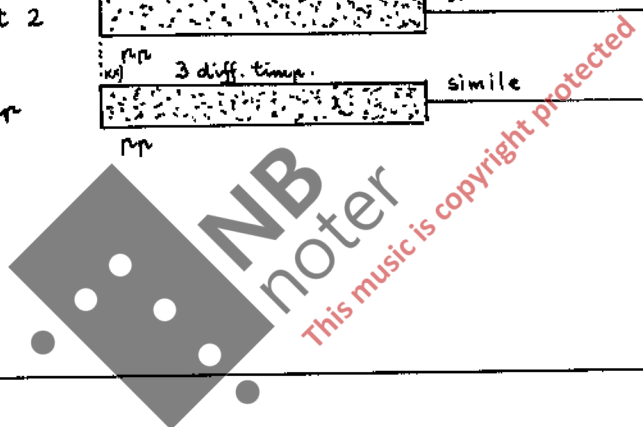

4 Senza tempo, quasi lento, accel e rall ad lib.

Fl. 1. *staccatissimo* *p* *simile*

Fl. 2. *staccatissimo* *p* *simile*

Fl. 3. *staccatissimo* *p* *simile*

Ob. 1. *staccatissimo* *p* *simile*

Cl. 1. *staccatissimo* *p* *simile*

Cor 1, 2. *con sord.* *p*

Cor 3, 4. *con sord.* *p*

Tr

Tib

Batt

Temp

Senza tempo, quasi lento, accel. e rall ad lib.

Vn I. *col legno battuto sul pontic. con sord.* *p* *simile* *clb. sp.* *p* *sim.*

Vn II. *clb. s.p. con sord.* *p* *simile* *clb. sp.* *p* *sim.*

Vl. *clb. sp. con sord.* *p* *simile* *clb. sp.* *p* *sim.*

Ve. *Con sord. Pizz. sub tasto vibr.* *p* *simile*

Cb. *Con sord. Pizz. sub tasto vibr.* *p* *simile*

x = not synchronized

The score is divided into several sections:

- FL (Flute):** Three staves with staccatissimo and sim. markings.
- Ob. (Oboe):** One staff with staccatissimo and sim. markings.
- Cl. (Clarinet):** One staff with staccatissimo and sim. markings.
- Cl.b. (Bass Clarinet):** One staff with staccatissimo and sim. markings.
- Fg. (Fagotto):** Two staves with staccatissimo and sim. markings.
- C.fg. (Contrafagotto):** One staff with staccatissimo and sim. markings.
- Cor (Corni):** Three staves with staccatissimo and sim. markings.
- Tr. (Trombe):** Three staves (1, 2, 3) with staccatissimo and sim. markings, including a 'straight mute' instruction.
- Batt. (Batterie):** Two staves with dynamic markings.
- Timp. (Timpani):** One staff with dynamic markings.
- Vn. (Violini):** Two staves (I and II) with staccatissimo and sim. markings, including 'sul D' and 'sul C' instructions.
- Vl. (Viola):** One staff with staccatissimo and sim. markings, including 'sul C' instruction.
- Vc. (Violoncello):** One staff with staccatissimo and sim. markings, including 'sul C' instruction.
- Cb. (Contrabbasso):** One staff with staccatissimo and sim. markings, including 'sul C' instruction.

x) col legno, glissando, batt. saltato

FL.

Ob.

Cl.

Cl. b.

Fg.

E. fg.

Cor

Tr.

Trb.

Batt

Tlmp.

Piano

Ped.

Vn I

Vn II

Vl

Ve

Cb

legato (con sord.) sim.

legato (con sord.) sim.

legato sim.

legato sim.

staccatissimo sim.

staccatissimo sim.

staccatissimo sim.

3 bongos + 3 tamburi militari (fingertips) senza corde

tam. rull + gr. cassa (fingertips)

mp

Ped

Pizz + gliss. sim.

Pizz + gliss. + vibr. sim.

Pizz + gliss. sim.

Pizz + gliss + vibr. sim.

Pizz + gliss + vibr. sim.

play with whisksers (spazzola) directly on the strings.



Quasi Allegretto, accel e rall ad lib.

FL 1. *staccatissimo* *mp* *b<sub>e</sub>* *tr* *sim.*

FL 2.3 *staccatissimo* *mp* *tr* *sim.*

Ob 1. *staccatissimo* *mp* *tr* *sim.*

Ob 2.3 *staccatissimo* *mp* *tr* *sim.*

Cl 1.2. *staccatissimo* *mp* *tr* *sim.*

Cl.b *staccatissimo* *mp* *tr* *sim.*

Fg *staccatissimo* *mp* *tr* *sim.*

C.fg *staccatissimo* *mp* *tr* *sim.*

Cor

Tr.

Trb.

Batt *mp*

Timp *mp*

Pno *mp* *Ped.*

Quasi Allegretto, accel e rall ad lib.

Vn I

Vn II

Vl *arco* *div. gliss* *mp* *sim.*

Ve

Cb

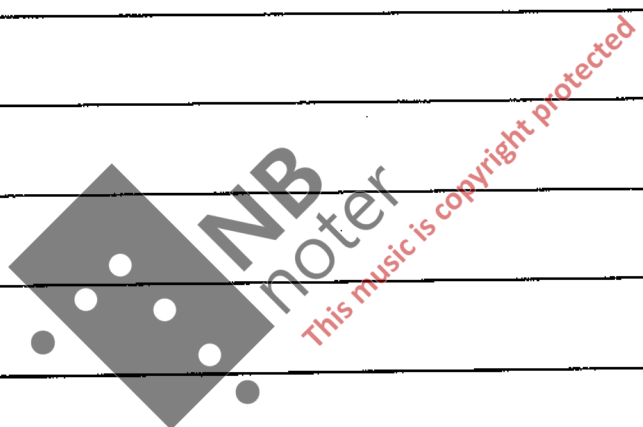



Fl  
Ob  
Cl.  
Cl.b  
Fg  
C.fg  
Cor  
Tr  
Trb.  
Batt  
Timp  
Pno  
I Vn  
II Vn  
Vl  
Ve  
Cb

staccatissimo  
mf  
sim.  
staccatissimo  
mf  
sim.  
staccatissimo  
mf  
sim.  
staccatissimo  
mf  
sim.  
staccatissimo  
mf  
sim.  
Flutterzunge  
staccatissimo  
mf  
sim.  
Flutterzunge  
staccatissimo  
mf  
sim.  
Flutterzunge  
staccatissimo  
mf  
sim.  
mf  
3 bongas + 3 tam. m + 2 casse di legno, make dry sounds.  
mf  
tam. rull + gr. cassa + 2 casse di legno, make dry sounds  
mf  
dry sounds  
mf  
mf  
Ped  
arco  
div. gliss.  
mf  
sim.  
arco  
div. gliss.  
mf  
sim.  
arco  
div. gliss.  
mf  
sim.  
arco  
div. gliss.  
mf  
sim.

♯ = brachette morbide      ▼ pitch as low as possible

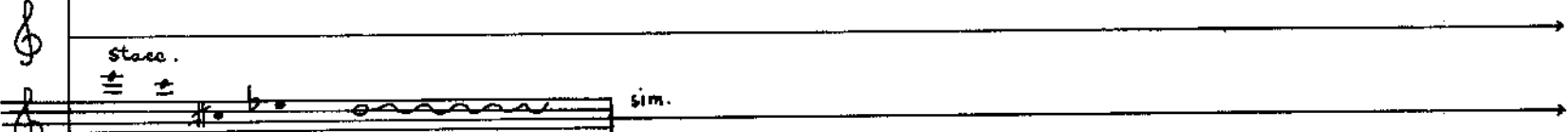
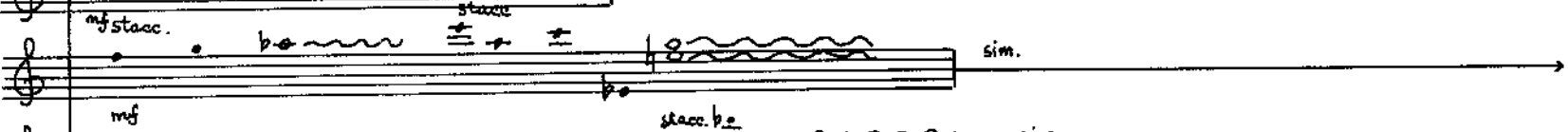
FL. 

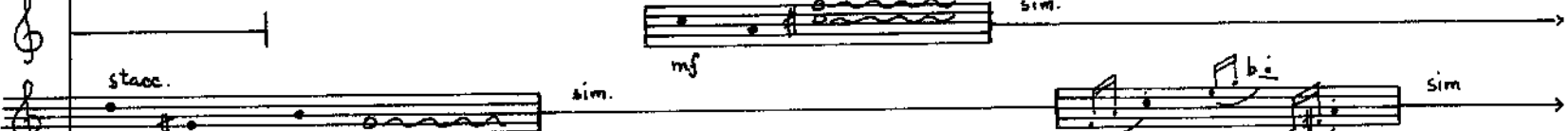
Ob. *stacc.*   
*mf stacc.* 

Cl. *mf*   
*stacc. mf* 

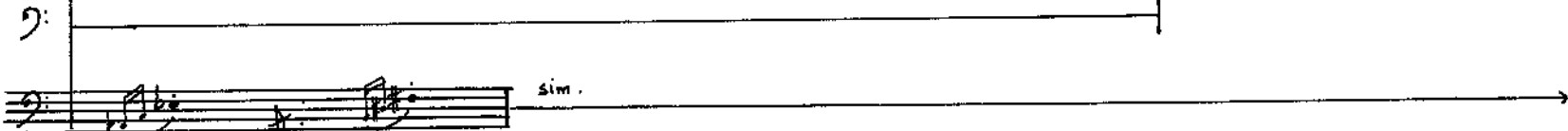
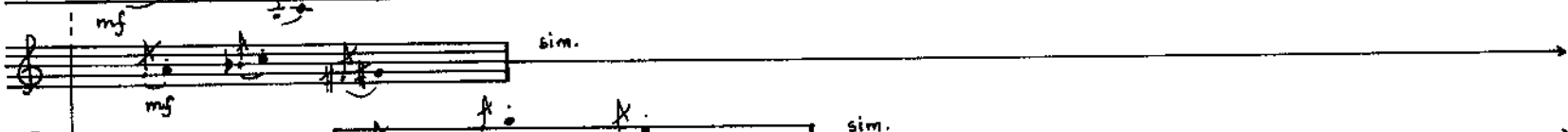
Cl. b. *stacc. mf*   
*f* 

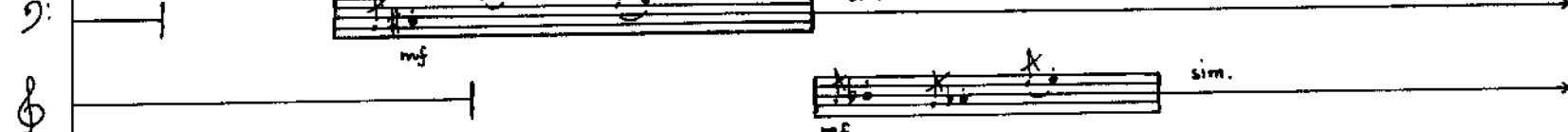
Fg. 

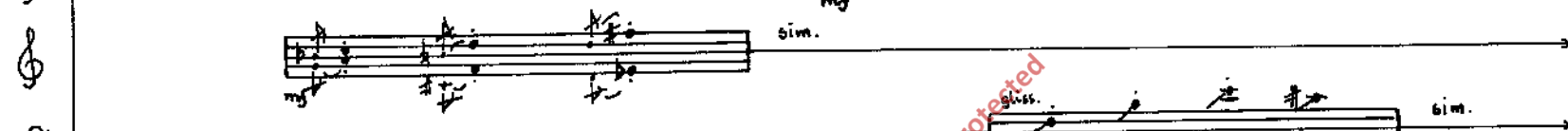
C. fg. *mf* 

Cor. *mf* 

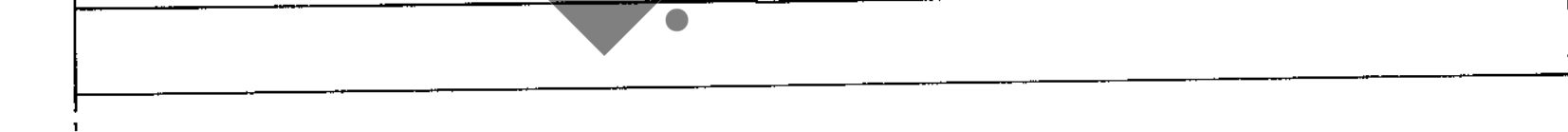
Tr.   
*mf* 

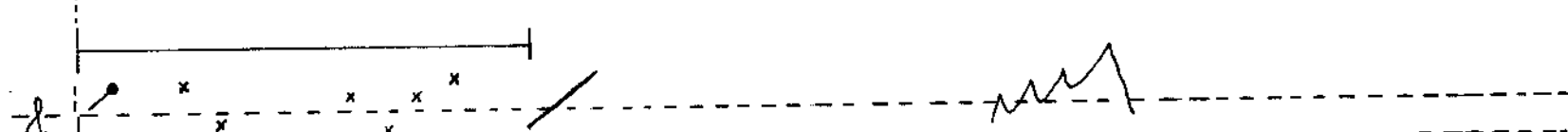
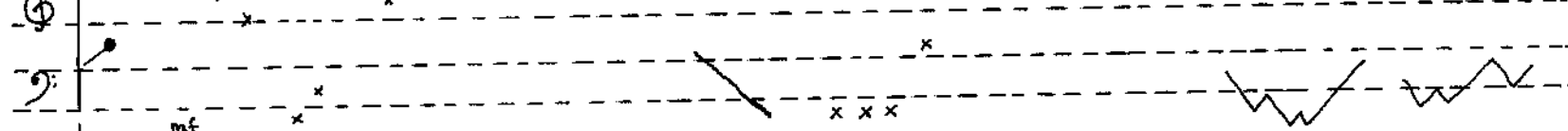
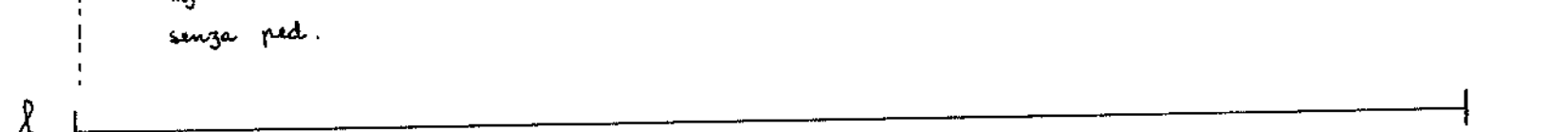
Trb. *f* *gliss.*   
*f* *gliss.*   
*f* *gliss.* 

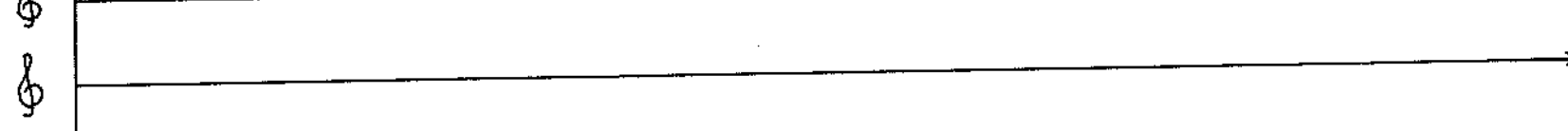
Batt. 

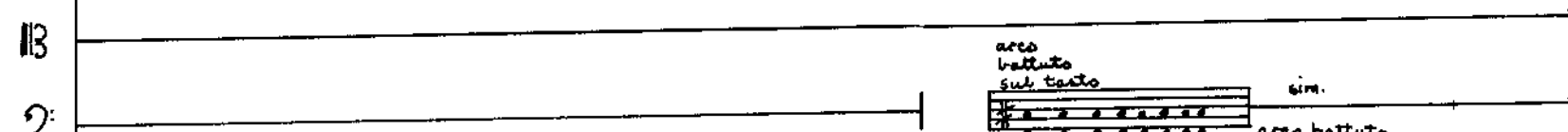
Timp. 

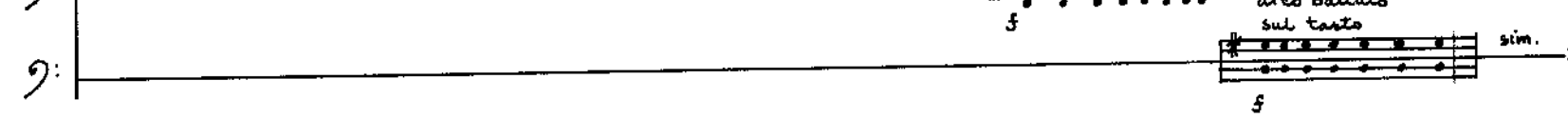
Pno. *mf* *senza ped.* 

Vn. I 

Vn. II 

Vl. 

Vc. *f* *arco battuto sul tasto*   
*f* *arco battuto sul tasto* 

Cb. 

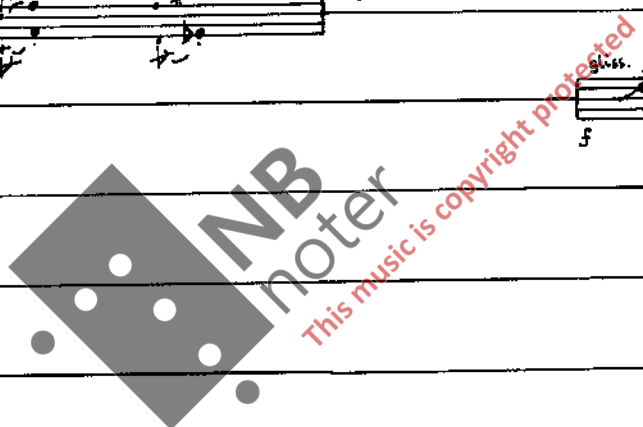

FL

Ob

Cl.

Cl.b

Fg

C.fg

Cor

Tr

Trb

3 Bongos

sand block

Va I

Va II

Vl

Ve

Cb

stacc

sim.

f

stacc.

f

stacc

f

(gliss)

f 1.

f 2.

(gliss)

sim.

senza sord.

senza sord.

sim.

sim.

3 tam. milit

mf

3 casse di legno

mf

Ped

f

arco battuto dir. sul tasto

sim.

f

arco battuto dir. sul tasto

sim.

f

arco battuto sul tasto

sim.

f

senza sord.

Pizz

f

sim.

Quasi Allegro, accel e rall ad lib.

FL *f* (gliss) *sim.* *ff* (gliss) *sim.*

Ob

Cl. *sim.*

Cl. b. *f* *sim.*

Fg *f* *sim.*

C. fg *f* *sim.*

Cor *f* *sim.* *crec.* *sim.* *crec.*

Tr *senza sord.* *senza sord.* *sim.*

Trb. *I- VII* *f* *sim.* *I- VII* *f* *sim.*

3 tom-tom *f*

2 ptti. sosp *f*

2 casse di legno *f*

2 ptti sosp *f*

taw. rull. ord. sticks *f*

staccatissimo

Ord. clusters (ea. tier)

Senza ped

Quasi Allegro, accel e rall ad lib

Vn I *senza sord.* *Pizz.* *f* *sim.*

Vn II *senza sord.* *Pizz.* *f* *sim.*

Vl *senza sord.* *Pizz.* *f* *sim.*

Ve *arco, staccato* *ff* *sim.*

Cb *Pizz.* *f* *sim.* *arco, stacc.* *senza sord.* *ff* *sim.*

glissando (arpeggio) along the harmonics



FL (flute) *ff* (gliss) *sim.*

Ob (oboe) *ff* *sim.*

Cl (clarinet) *ff* *sim.*

Cl.b. (clarinet in bass) *ff* *sim.*

Fg (fagotto) *ff* *sim.*

C.fg (contrabbasso) *ff* *sim.*

Cor (corni) *ff* *sim.*

Tr (trombe) *ff* *sim.*

Trb (tromboni) *ff* *sim.*

2 ptti sarp. (2 percussioni) *f* *senza sord.*

2 casse di l. (2 tamburi) *f* *senza sord.*

2 casse di l. (2 tamburi) *f* *frusta* *senza sord.*

Timp (timpani) *f* *estinato simile*

Pno (pianoforte) *ff*

Va I (violino I) *ff* *arco, stacc.* *sim.*

Va II (violino II) *ff* *arco, stacc.* *sim.*

Vl (viola) *ff* *arco, stacc.* *sim.*

Vc (violoncello)

Cb (contrabbasso)

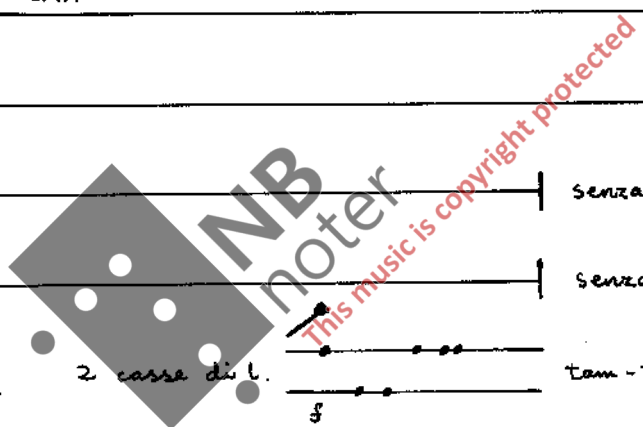

Accelerando

FL. *ff* *sim.*

Ob *ff* *sim.*

Cl. *ff* *sim.*

Cl. b *ff* *sim.*

Fg *ff* *sim.*

C. fg *ff* *sim.*

Cor *ff* *sim.*

Tr. *ff* *sim.*

Trb I *ff* *sim.*

3 tom-tom

2 casse di l. *ff*

Timp *ff*

Pno *ff* Senza ped

Accelerando

Vn I *ff* *arco* *sim.*

Vn II *ff* *arco* *sim.*

Vl *ff* *arco* *sim.*

Ve *ff* *arco* *sim.*

Cb. *ff*

This musical score page, numbered 14, contains the following parts and markings:

- Flute (Fl):** *diatonic*, *fff*
- Oboe (Ob):** *diatonic*, *fff*
- Clarinet (Cl):** *diatonic*, *fff*
- Bassoon (Cl.b):** *diatonic*, *fff*
- Bassoon (Fg):** *diatonic*, *fff*
- Contrabassoon (C.fg):** *diatonic*, *fff*
- Cor:** *fff*, *sim.*
- Trumpet (Tr.):** *fff*, *sim.*
- Trombone (Trb):** *fff*, *sim.*
- Percussion:**
  - 3 tom-tom:** *fff*, *Rimshot*, *3 bangos*, *fff*
  - Tam. rull:** *fff*, *frusta*, *fff*
  - Timp.:** *fff*
- Piano (Pno):** *fff*
- Violin I (Vn I):** *diatonic*, *fff*
- Violin II (Vn II):** *diatonic*, *fff*
- Viola (Vl):** *diatonic*, *fff*
- Violoncello (Vc):** *diatonic*, *fff*
- Double Bass (Cb):** *arco*, *fff*, *sim.*

NB noter  
This music is copyright protected



Quasi Presto

Fl

Ob

Cl

cl.b.

Fg

Cfg

Cor

Tr.

Trb.

Tam-tam piccolo

Tam-tam medio grande

Timp.

Pno

Quasi Presto

Ped.

Vn I

Vn II

Vl

Ve

Cb

diatonic

stacc.

I - VII

fff

sim.

sim.

sim.

sim.

diatonic

fff

Batterie

FL  
f pass. NB

Ob  
f pass. NB

Cl  
f pass. NB

Cl.b  
f pass. NB

Fg  
f pass. NB

C.fg  
f pass. NB

Cor  
f pass. NB

Tr.  
f pass. NB

Trb.  
f pass. NB

Tmp  
f pass. NB

Tam-tam piccolo  
f pass.

Tam-tam medio grande  
f pass.

Pno  
f pass. Ped.

I  
sim.

Vn  
f possibile

Vl  
f pass.

Ve  
f pass.

Cb  
f pass.

Tras. (made ord.)  
mf

Tras. (made ord.)  
mf

Tras. (made ord.)  
mf

Tras. (made ord.)  
mf

Tras. (made ord.)  
mf

Tras. (made ord.)  
mf

NB: Continue to play diatonic leaps → batterie

(Fl.) TKTKT? *sim.*  
p - mf

(Ob) TK? TK? *sim.*  
p - mf

(Cl.) TKT? *sim.*  
p - mf

(Cl.b) F  
p - mf

(Fg) SH  
p - mf

(C.fg.) H H H  
p - mf

(Cor) TKTK *sim.*  
p - mf

(Tr.) TK? TKT *sim.*  
p - mf

(Trb.) S S S  
p - mf

Z  
p - mf

M M  
p - mf

M  
p - mf

M  
p - mf

Batt I *Improvvisando, skin instr. fingertips, make dry sounds. p - mf sim.*

Batt II *Improvvisando, skin instr. fingertips, make dry sounds. p - mf sim.*

Temp. *Improvvisando, fingertips, dry sounds. p - mf sim.*

Pno *Filtration on the strings*

Ped

Vn I *molto sul pontic. p - mf*

Vn II *molto sul tasto*

Vl *molto sul pontic. p - mf*

Ve *molto sul tasto p - mf*

Cb. Solo *Appassionato*

Cb *molto sul pontic. p - mf*

T, K, F, SH, H, S = without voices      Z and M = voiced

(Fl.)

(Ob.)

(Cl.) SH- / SH-

(Cl.-b.) H- H- H- H- H-

(Fg.)

(E.fg.)

(Cor.) S- S-

(Tr.)

(Trb.)

Batt.

Timp.

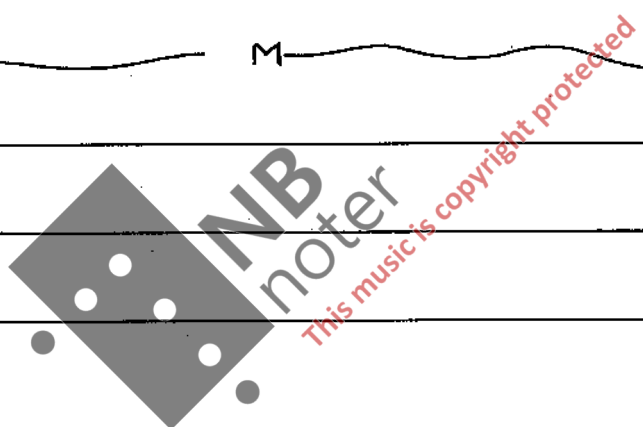

Pno

Ped.

I *molto sul tasto*

Vn *modo ord.* *molto sul pontic.*

II *modo ord.* *molto sul tasto*

VL *modo ord.* *molto sul pontic.*

Vc *modo ord.* *molto sul pontic.*

Cb. Solo *Agitato*

Cb. *modo ord.* *molto sul pontic.*



(Fl) S SH S

(Ob) S Z S SH

(Cl) S

Cl.b S

(Fg) SH

(C.fg) SH **DGD'** sim.

(Cor) Instr. **D'D'** sim.

(Tr) SH **DGDG** sim.

(Tbn) Z Z

Batt 2 pffl sosp.

Temp

Pno *Fingertips, the "nailside"*  
gliss.  
Ped.

Vc arco misto **col legno batt. sul pontic.**

Vn arco misto **col legno batt. sul pontic.**

Vl **col legno batt. sul pontic.**

Vc **col legno batt. sul pontic.**

Vc.Solo *Pizz. p*

Cb Solo **col legno batt. sul pontic.**

Cb **col legno batt. sul pontic.**

D and G = voiced

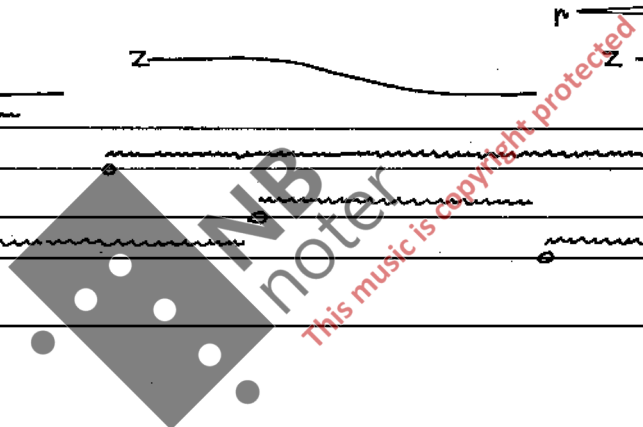

(Fl) Instr. *1. full* *mp* *mf* **T'T'T'** *sim.*

**DGD** *sim.*

(Ob) **GD'GD'** *sim.*

**D'D'D'** *sim.*

(Cl) **DG'DG'** *sim.*

(Cl.b) **TK'TK'** *sim.* Instr. *mp* *mf*

(Fg) **TKT'TKT** *sim.*

(C.fg) Instr. *mp*

(Cor) *p* 1.2.4. **X X X X X X** *sim.* Instr. *mp* *mf* **T'T'** *sim.*

(Tr.) Instr. *mp* *mf*

(Tr.b) **TK'TK'TK'TK'** Instr. *mp* *mf* **X X X X X X** *sim.*

2 ptti *Tam-tam piccolo*

2 ptti *Tam-tam media grande*

Temp

Pno Tremolo with the fingertips (nailside) *sim.* *p* Senza ped.

Ve I *p* Pizz. ord. possibile presto

Ve II *p* Pizz. ord. possibile presto

Vl *p* Pizz. ord. possibile presto

Ve *p* Pizz. ord. possibile presto

Ve Solo *p*

Cb Solo *p*

Cb *p* Pizz. ord. possibile presto

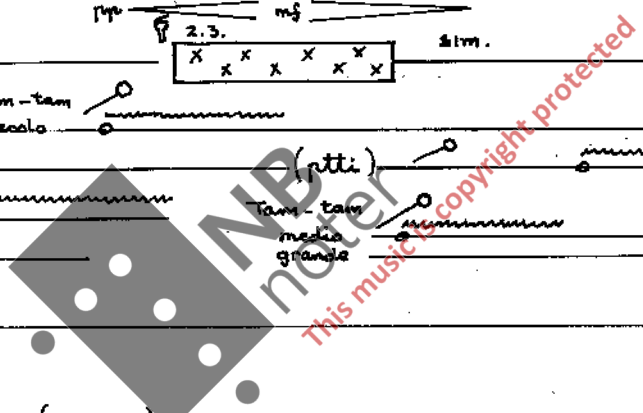

(Fl) *1. frull.* *pp* *mf* *S*  
 (Ob) *Insta.* *pp* *mf* *S*  
 (Cl.) *S*  
 (Cl.b) *T K T K* *sim.* *S*  
 (Fg) *S* *pp* *mf*  
 (C.fg) *mf* *pp* *mf* *S*  
 (Cor) *SH*  
 (Tr) *T' T'* *sim.* *1. +o+o* *pp* *mf* *SH*  
 (Trb) *1. +o+o* *pp* *mf* *SH*  
 Batt *l.v.*  
 Timp *l.v.*  
 Pno  
 Vn I *senza arco* *pp*  
 Vn II *senza arco*  
 Vl *senza arco* *pp*  
 Vc *senza arco* *pp*  
 Cb. solo *molto espressivo* *f*



(Fl.)

(Ob.)

(Cl.)

(Cl.b.)

(Fg.)

(E.fg.)

(Cor.)

(Tr.)

(Tr.b.)



This music is copyright protected

I  
 Vn *dim* *ppp*  
 II *dim* *ppp*  
 VI *dim* *ppp*  
 Ve *dim* *ppp* *molto espressivo*  
 Ve. solo *f* *pp*  
 Cb. solo *f* *pp*  
 Cb. *dim.*